

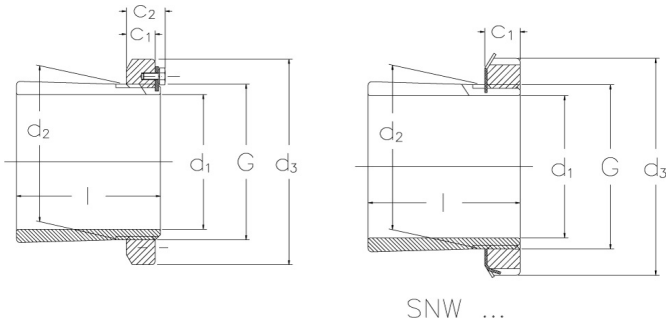

SNW 8-1 5/16

Adapter sleeves with inch dimensions



Technical data

d1 (Inch)	1 5/16
d2 (mm)	40
l (Inch)	1.504
d3 (Inch)	2 1/4
G (Inch)	1.563
c1 (Inch)	0.495
c2 (Inch)	-
Threads per inch	18
Weight (kg)	0.19

Related products

N-08

Locknuts with inch dimensions

W-08

Locking washers with inch dimensions