

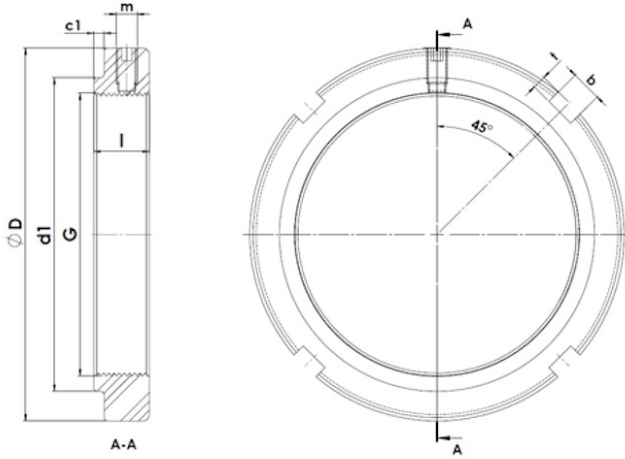

KMS1-30

Lock nut with integrated clamping element



Technical data

G	M150x2
l (mm)	30
D (mm)	195
d1 (mm)	162
c1 (mm)	9
m	M10
b (mm)	14
t (mm)	6
Weight (kg)	2.27