

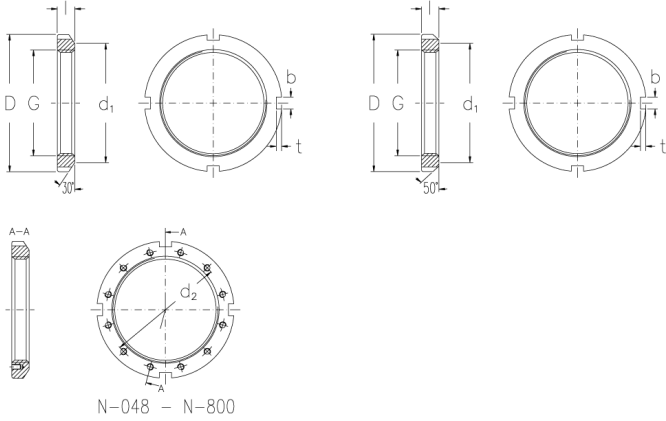

N-052

Muttern mit Zoll-Abmessung



Technische Daten

G (Inch)	10,192
Gewindegänge pro Zoll	6
l (Inch)	1,416
D (Inch)	12,193
d1 (Inch)	11,406
b (Inch)	0,86
t (Inch)	0,385
d2 (Inch)	11,298
Gewicht (kg)	5,1
Schraube	5/16 - 18-5/8

GTIN/EAN

