

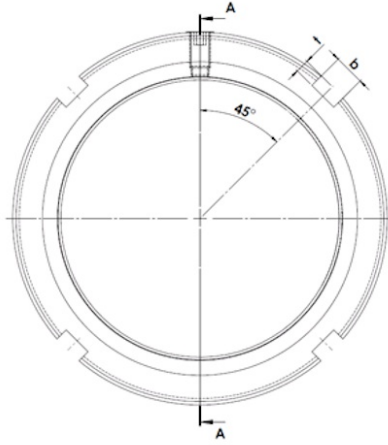

KMS1-16

Wellenmutter mit integriertem Sicherungselement



Technische Daten

G	M80x2
l (mm)	18
D (mm)	105
d1 (mm)	91,5
c1 (mm)	3
m	M8
b (mm)	8
t (mm)	3,5
Gewicht (kg)	0,48